

## YCW1 & YCW2

Y-STRAINER, 150# & 300#, BUTT WELD  
Cast Carbon Steel (ASTM A-216, Grade WCB)

### STANDARD SCREENS

SIZE (in)	SCREEN PERFORATION			
	STEAM		LIQUID	
	(in)	OPEN AREA	(in)	OPEN AREA
1/2 TO 4	3/64	33%	1/16	30%
5 TO 10	3/64	33%	1/8	43%
12	1/16	30%	1/8	43%

The default standard screens are for liquid service unless specified. Many other options are available.

### PARTS LIST

ITEM	DESCRIPTION	MATERIAL
1	BODY	CAST CARBON STEEL (ASTM A216, GR WCB)
2	SCREEN (BASKET)	STAINLESS STEEL (304)
3	GASKET	STAINLESS STEEL-SPRIAL WOUND (304)
4	COVER	CAST CARBON STEEL (ASTM 216, GR WCB)
5	STUDS	CARBON STEEL (ASTM A 193, GRADE B7)
6	NUTS	CARBON STEEL (ASTM A 194 GRADE 2H)

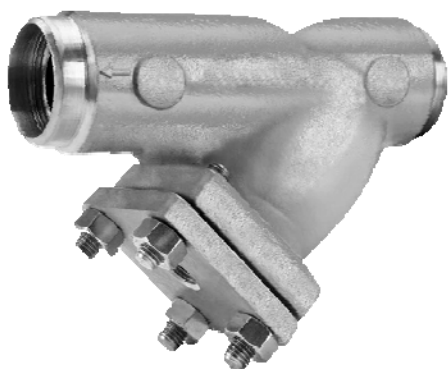
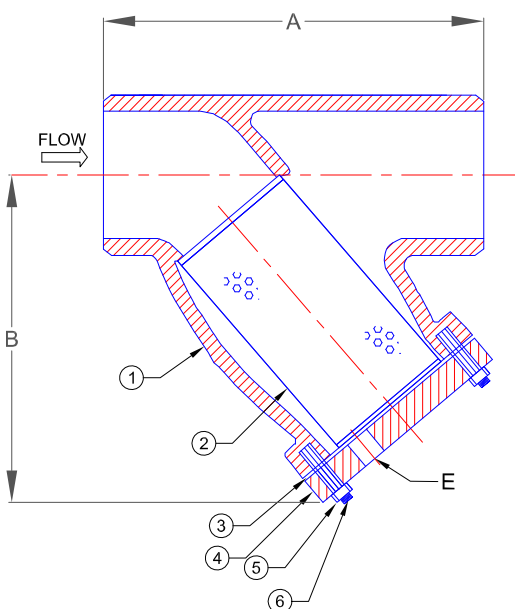

### DIMENSIONS & WEIGHT

SIZE (in)	A		B		E		WT (lbs)	
	150#	300#	150#	300#	150#	300#	150#	300#
1/2	6-1/2	6-1/8	3-3/4	3-3/4	3/8	3/8	7	6
3/4	7-3/8	7-3/4	4-1/4	4-1/4	1/2	1/2	11	13
1	7-3/8	7-7/8	4-1/4	4-1/4	1/2	1/2	11	13
1-1/4	7	8-1/8	5-1/8	5-1/8	1/2	1/2	12	19
1-1/2	7-1/8	8-1/4	5-1/8	5-1/8	1/2	1/2	14	19
2	7-7/8	9-1/2	6-1/16	6-1/16	1/2	1/2	22	33
2-1/2	9-3/4	10-3/8	6-1/2	6-1/2	1	1	32	44
3	10-1/16	12	7-7/16	7-5/16	1	1	41	58
4	12-1/8	14-1/2	8-15/16	8-15/16	1-1/2	1-1/2	63	90
5	15-1/2	19-5/16	13-3/8	13-3/8	2	2	111	180
6	18-1/2	19-5/16	13-1/8	13-1/8	2	2	136	180
8	21-3/8	23-3/8	15-11/16	15-7/8	2	2	212	304
10	26	27-3/8	18-7/16	18-7/16	2	2	280	470
12	29-7/8	32	21-3/16	23-1/16	2	2	460	709

### FLOW COEFFICIENTS

SIZE (in)	Cv	SIZE (in)	Cv
2	62	6	942
2-1/2	98	8	942
3	155	10	1572
4	269	12	2261
5	364		

### SCREEN AREA (150#)

SIZE (in)	SQ IN	SIZE (in)	SQ IN
2	30	6	241
2-1/2	47	8	343
3	58	10	533
4	92	12	601
5	209		

See elsewhere for calculating Net Free Area.

### PRESSURE VS. TEMPERATURE

